

ALUMINUM WELD DEFECTS REDUCE STRUCTURAL INTEGRITY

MAJOR WELD DEFECT TYPES

Defect Type 1: Porosity

Problem: Reduced weld strength and lower fatigue resistance
Cause: Hydrogen gas dissolved in the molten weld
Source: Moisture, grease or other hydro-carbons in weld zone

Defect Type 2: Oxide Inclusions

Problem: Reduced weld strength and lower fatigue resistance
Cause: Aluminum oxide is not destroyed in the welding process
Source: Natural-occurring aluminum oxide on material prior to welding

ALUMINUM IS NOT LIKE STEEL

Oxide Stability: The oxide which occurs naturally on steel is destroyed during the welding process. Aluminum oxide is not destroyed during aluminum welding and must be removed prior to welding.

Thermal Expansion: When heated, aluminum expands twice as much as steel. As a result, warping and bending are significant issues.

Electrical Conductivity: Since aluminum conducts electricity better than steel, welding parameters like amperage must be adjusted for different conductance.

THE DIFFERENCE

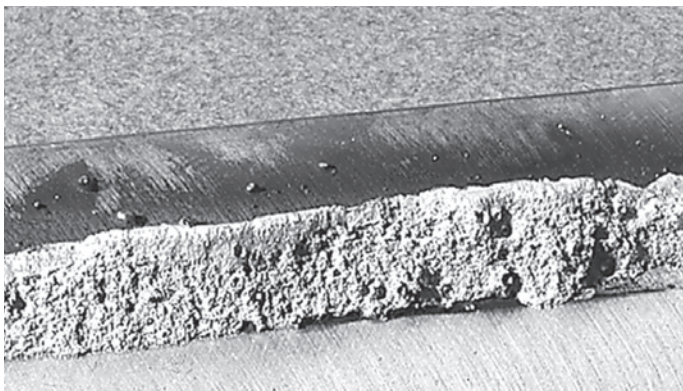

Aluminum weld without proper weld preparation exhibits porosity. Result - unacceptable weld.



Aluminum weld with proper weld preparation shows no pores. Result - acceptable weld.

SOLUTIONS FROM THE EXPERTS

Minimize weld porosity

"Prior to welding, the first operation should be to remove all grease, oil, dirt, paint, or other surface contaminants that can generate hydrogen gas or interfere with weld fusion." - *Oates; Welding Handbook*

"All hydrogen containing compounds, such as moisture, water vapor, oil and grease, must be removed from the weld zone by degreasing and drying." - *Baumeister; Marks' Standard Handbook for Mechanical Engineers*

Minimize oxide inclusions

"Welding procedures also call for the removal of the thin, tough, transparent film of aluminum oxide that forms..." - *Baumeister; Marks' Standard Handbook for Mechanical Engineers*

"Degreasing should be followed by scratch brushing of surfaces to be welded, with a hand or power-driven stainless steel brush... the (time) interval between cleaning of the joint and welding should be as short as possible." - *Structural Welding Code - Aluminum*

THE GOAL: HIGHEST QUALITY ALUMINUM WELDS

DEGREASED STAINLESS PRODUCTS FOR WELD PREP

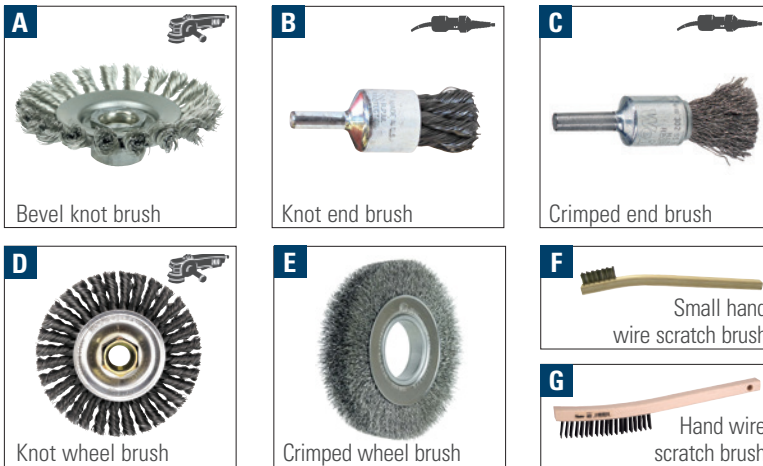

“Thick aluminum oxide should be removed with a power-driven stainless steel brush...”
- *Structural Welding Code - Aluminum*

All of Weiler’s brushes for aluminum weld preparation are designed to provide maximum cleaning efficiency without depositing grease or oil in the work area.

For best results, “brushes should be used with light pressure to avoid burnishing the aluminum surface and entrapping oxide particles.” - *Oates; Welding Handbook*

NOTE: Specialty applications for the above products are shown in the schematics below. Products F & G are used in a wide variety of general purpose applications. For specific product/application information, contact Weiler.

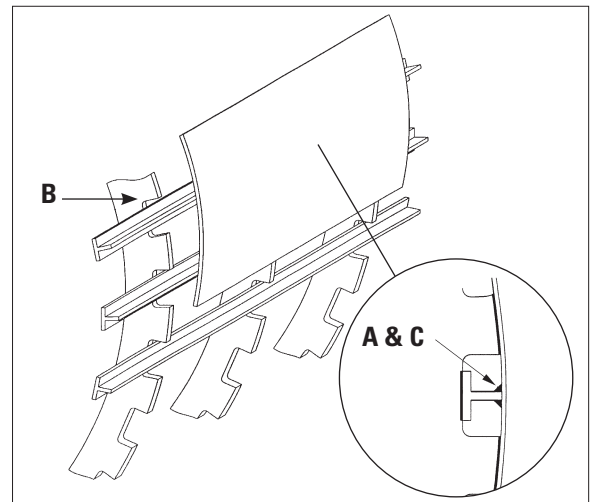
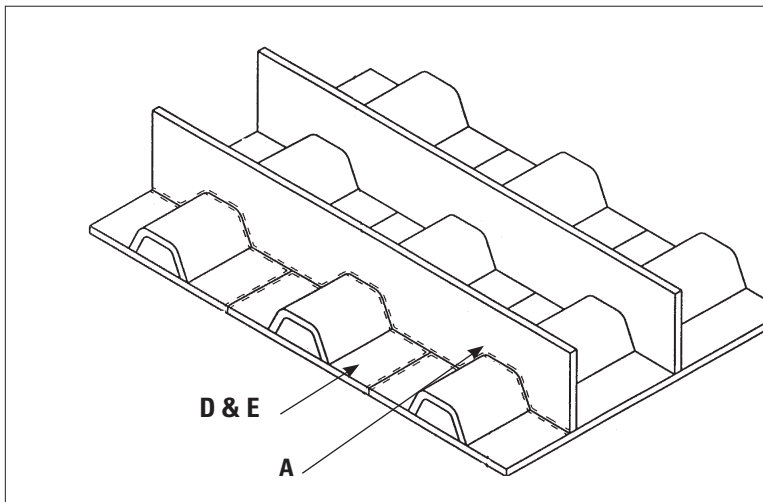

PRODUCTS FOR ALUMINUM GRINDING



Big Cat™ discs are ideal for use on flat surfaces. They are especially well-suited for smoothing edges following cutting operations.

Resin Fiber discs are a general purpose grinding tool.

AL-tra CUT™ discs are designed to **prevent loading** in applications where weld blending is required. AL-tra CUT discs should not be used during weld preparation.

CAUTION

“Grinding or sanding with wheels or discs can be done with proper materials, although it is easy to imbed abrasive particles in the aluminum surface that may result in unacceptable inclusions in the weld.”
Oates; Welding Handbook